

DESIGN NOTES

Compact Triple Step-Down Regulator Offers LDO Driver and Output Tracking and Sequencing – Design Note 441

Tiger Zhou

Introduction

Typical industrial and automotive applications require multiple high current, low voltage power supplies to drive everything from disk drives to microprocessors. The LT[®]3507 triple step-down converter fits easily into these applications. It is simple and compact compared to multi-chip solutions.

The LT3507 is a single IC current mode triple step-down regulator with internal power switches and a low dropout linear regulator driver. The switching converters are capable of generating one 2.4A output and two 1.5A outputs. All three converters are synchronized to a single oscillator, with the 2.4A output running antiphase to the other two converters, thereby reducing input ripple current. Each converter has independent shutdown and soft-start circuits and generates a power good signal when its output is in regulation, simplifying both supply sequencing and the interface with microcontrollers and DSPs. Separate input pins for each regulator offer additional flexibility; regulators can be cascaded to reduce circuit size, or each regulator can draw power from a different input source.

The switching frequency is set with a single resistor between 250kHz to 2.5MHz. High switching frequency allows the use of small inductors and capacitors resulting in a very compact triple output supply. The constant switching frequency, combined with low impedance ceramic capacitors, results in low output ripple. With its wide input voltage range of 4V to 36V, the LT3507 regulates a broad array of power sources including 5V logic rails, unregulated wall transformers, lead acid batteries and distributed power supplies.

6V to 36V Input to Four Outputs—1.8V, 3.3V, 5V and 2.5V—One IC

The triple converter accommodates a 6V to 36V input voltage range and is capable of supplying up to 2.4A, 1.5A and 1.5A, respectively. The 20mA LDO driver output can drive an NPN transistor to provide a fourth low

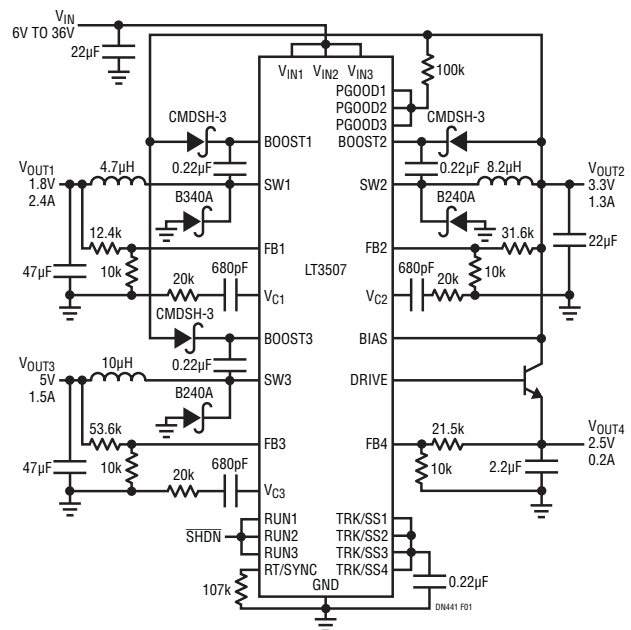

Figure 1. A 4-Output Supply Including a Low Noise LDO

noise rail. Figure 1 shows a typical application for four outputs—1.8V at 2.4A, 3.3V at 1.3A, 5.0V at 1.5A and 2.5V at 0.2A—from a 6V-36V input supply.

Low Ripple High Frequency Operation Even at High VIN/VOUT Ratios

High frequency operation minimizes solution size, but one obstacle to high voltage (36V), high frequency (MHz) operation of monolithic step-down regulators is the minimum on-time constraint. Due to an internal logic propagation delay, a step-down regulator must remain on for a minimum time interval for proper operation. Otherwise, the converter operates in pulse-skipping mode at high input-to-output ratios, which has the undesirable side effect of increasing output ripple. For example, the application in Figure 1 best operates at 450kHz when the input is 36V and the output is 1.8V.

LT, LT, LTC and LTM are registered trademarks of Linear Technology Corporation. All other trademarks are the property of their respective owners.

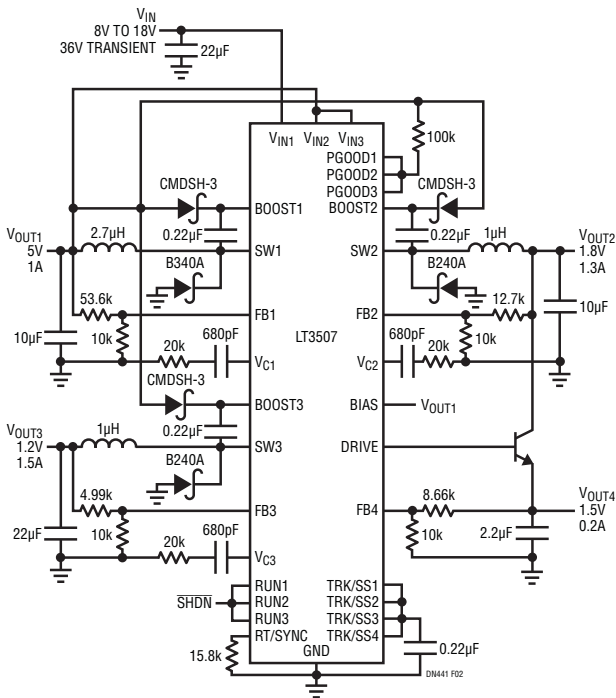

Figure 2. Cascading Supplies Maintain High Frequency Operation Even with High V_{IN}/V_{OUT} Ratios

However, the LT3507 has a built-in solution to this problem. By cascading the first converter and the other two, as shown in Figure 2, all three converters can be operated at 2MHz without pulse-skipping mode.

Input Voltage Lockout and Sequencing

The LT3507's under- and overvoltage lockouts can be programmed with external resistors. When the schematic in Figure 2 is modified as in Figure 3, the LT3507 will accept V_{IN} up to 36V but operate only when V_{IN} is between 8V to 18V. This prevents the IC from operating during unintended or fault conditions, allowing the circuit designer to reduce the size of the external components. Figure 3 also shows a simple sequencing scheme: channel 1's power good indicator is tied to the tracking pins of the other three channels. Figure 4 shows the resulting start-up sequence, with channel 1 starting first and the remaining channels tracking during their start-up. Other sequencing and tracking examples can be found in the data sheet.

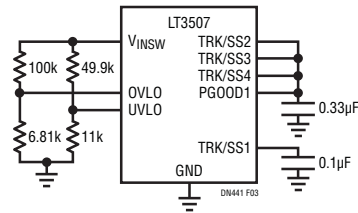

Figure 3. External Resistors Program the Input Voltage Lockout; PG00D1 Determines Sequencing and Tracking

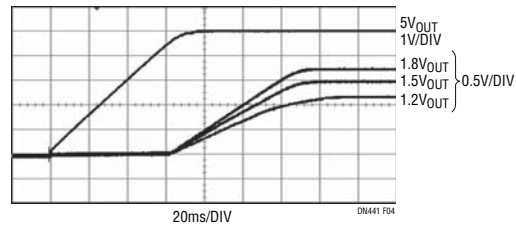

Figure 4. Channel 1 Starts First, the Others Follow and Track

An additional feature of LT3507 is the low noise LDO output. Figure 5 shows the LDO output ripple is reduced from the preregulated Channel 2 output.

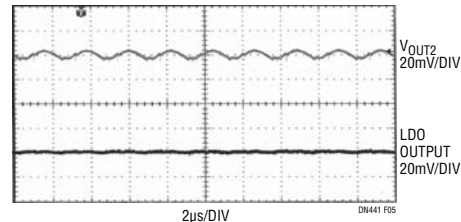

Figure 5. Low Noise LDO Output: Top Trace is Channel 2 Output, Bottom Trace is Channel 4 LDO Output

Conclusion

The LT3507 integrates three buck regulators and an LDO driver in a QFN (5mm × 7mm) package, offering a compact solution for multiple-rail systems. Separate inputs for each converter offer wide design freedom, while separate PG indicators and TRK/SS pins further extend tracking and sequencing flexibility.

[Data Sheet Download](#)

www.linear.com

For applications help,
call (408) 432-1900, Ext. 3223